

THE NETHERLANDS
(N E D E R L A N D)

EC TYPE-APPROVAL CERTIFICATE

Communication concerning the:

- type-approval ⁽¹⁾of a type of a ~~vehicle/component~~/separate technical unit ⁽¹⁾ with regard to Directive 70/221/EEC, as last amended by Directive 2000/8/EC.

Type-approval number : e4*70/221*2000/8*0552*00

Reason for extension : not applicable

SECTION I

- 0.1. Make (trade name of manufacturer) : Dautel
- 0.2. Type and general commercial description(s) : DLB 500/750-27X1D
DLB 500/750X1D
- 0.3. Means of identification of type if marked on the ~~vehicle/component~~/separate technical unit ^{(1) (2)} : not applicable
- 0.3.1. Location of that marking : not applicable
- 0.4. Category of vehicle ^{(1) (3)} : not applicable
- 0.5. Name and address of manufacturer : DAUTEL GMBH,
Dieselstraße 33, D-74211 Leingarten, Germany
- 0.7. In the case of components and separate technical units, location and method of affixing of the EC approval mark : see drawing 0088015, self adhesive factory plate
- 0.8. Address(es) of assembly plant(s) : DAUTEL GMBH,
Dieselstraße 33, D-74211 Leingarten, Germany

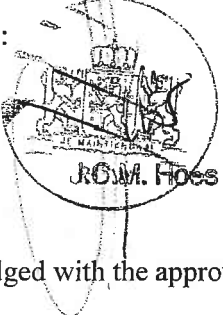

SECTION II

1. Additional information (where applicable) : see Addendum
2. Technical service responsible for carrying out the tests : TÜV NORD Mobilität GmbH & Co. KG,
IFM - Institut für Fahrzeugtechnik und Mobilität
Adlerstr. 7, 45307 Essen
3. Date of test report : 13.12.2005
4. Number of test report : 3681/05
5. Remarks (if any) : see Addendum
6. Place : Zoetermeer
7. Date : 14. FEB 2006
8. Signature : 
9. The index to the information package lodged with the approval authority, which may be obtained on request, is attached.

⁽¹⁾ Delete where not applicable.

⁽²⁾ If the means of identification of type contains characters not relevant to describe the vehicle, component or separate technical unit types covered by this type-approval certificate such characters shall be represented in the documentation by the symbol: "?" (e.g. ABC??123??).

⁽³⁾ As defined in Annex IIA to Directive 70/156/EEC.

ADDENDUM

to EC type-approval certificate number: e4*70/221*2000/8*0552*00

concerning the type-approval of a separate technical unit with regard to a rear underrun protective device (Directive 70/221/EEC, as last amended by Directive 2000/8/EC).

1. Additional information
 - 1.1. Construction
 - 1.1.1. Material : *)
 - 1.1.2. Method of affixing : *)
 - 1.1.3. Dimension of the device : *)
 - 1.2. Maximum technically permissible mass of the vehicle on which the device is to be mounted : *)
 - 1.3. Restrictions of the use of the device (if any) : none
5. Remarks:
none...

*) see enclosure

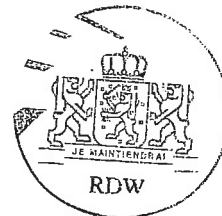



DAUTEL

Blatt 1 von 1

Beschreibungsbogen Nr. 20
Betreffend die EG-Typgenehmigung einer hinteren Unterfahrschutzeinrichtung
Als selbständige technische Einheit
(Richtlinie 70/221 EWG, zuletzt geändert durch die Richtlinie 2000/8 EG)

- | | | |
|-------|--|---|
| 0. | Allgemeines | |
| 0.1 | Fabrikmarke: | Dautel |
| 0.2 | Typ | DLB 500/750-27X1D |
| 0.2.1 | allgemeine Handelsbezeichnung | DLB 500/750X1D |
| 0.5 | Name und Anschrift des Herstellers | Dautel GmbH
D-74211 Leingarten |
| 0.7 | Lage und Anbringungsart des EG-Typgenehmigungszeichens: | Lage siehe Zeichnung
Fabrikschild
Selbstklebend |
| 0.8 | Anschrift der Fertigungstätte: | Dautel GmbH
Dieselstraße 33,
74211 Leingarten |
| 1 | allgemeine Baumerkmale des Fahrzeugs an das die Einrichtung angebracht werden Soll, soweit sie sich auf den hinteren Unterfahrschutz beziehen. | Fahrgestell mit Rahmenkonstruktion.
St. 37 $Re \geq 235 \text{ N/mm}^2$ |
| 1.1 | Mindestsumme der Tragheitsmomente An der horizontalen Achse der Längsträger Des Fahrgestell im Querschnitt | Haupt und Montagerahmen einer Seite Widerstandsmoment $W X = 60 \text{ cm}^3$ |
| 1.2 | Abstand Zwischen den Längsträgern des Fahrgestells an den Befestigungsteilen der Vorrichtung: | 690-1110 |
| 1. | Massen und Abmessungen | |
| 2.1 | Technisch zulässige Gesamtmasse: | 6000 kg |



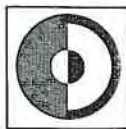

DAUTEL

Blatt 2 von 2

3 Aufbau

3.1 Ausführliche Beschreibung siehe Zeichnung *0088015 vom 05.11.05*

11.11.2005
Dautel GmbH
i. V. Klaus Schönberger



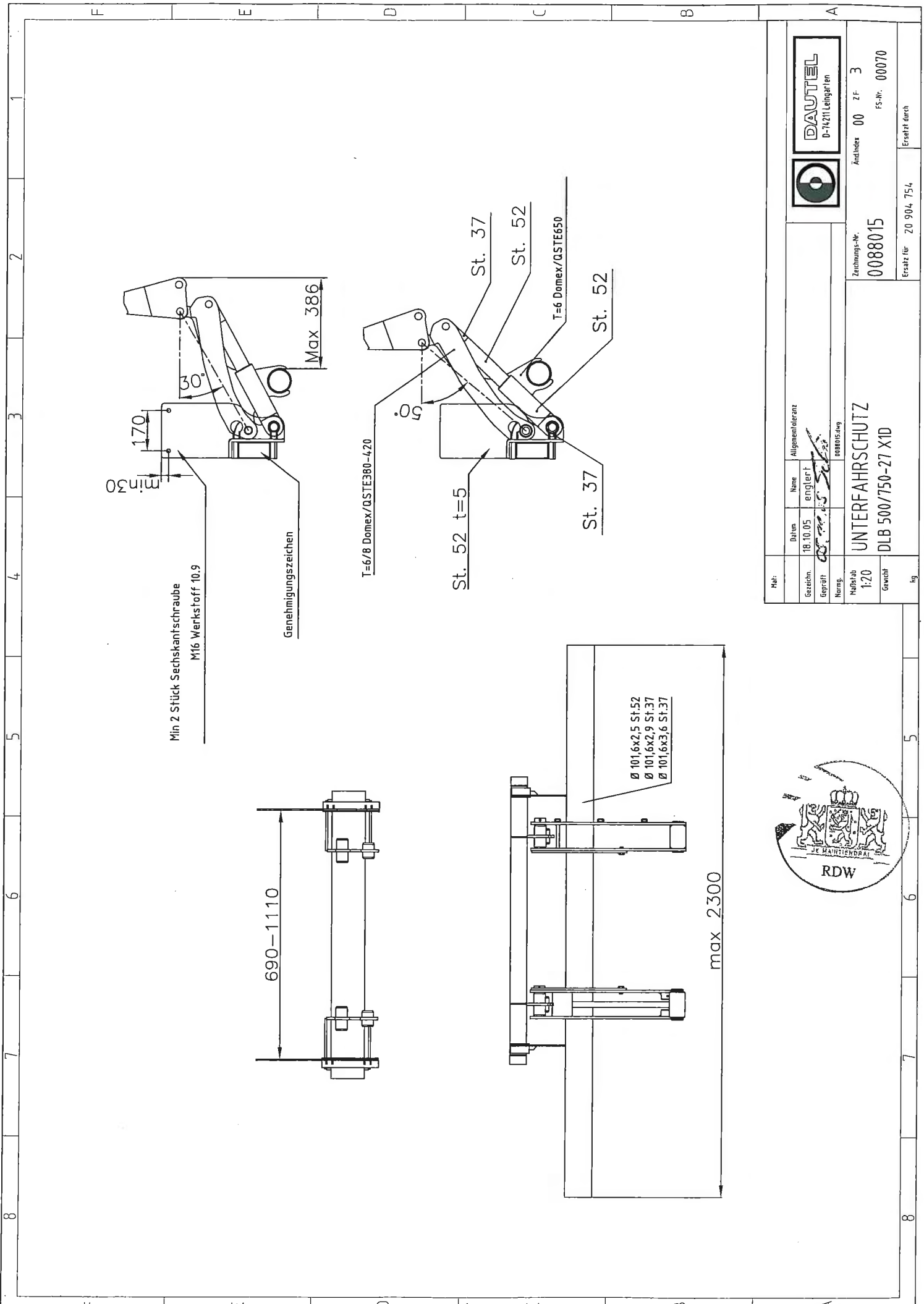

Ändlex 00 ZF 3
FS-Nr. 00070

Zerchungs-Nr.
0088015

Ersatz für 20 904 754

Maß:	Name: Allgemeintoleranz	
Gezeichnet:	Datum: 18.10.05	engeleitet
Geprüft:	<i>[Signature]</i>	
Nenngr.	Gepl. Änderung	
Maßstab: 1:20	UNTERFAHRSCHUTZ	
Gewicht:	DLB 500/750-27 X10	
kg		

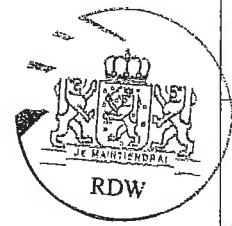

F 2 3 4 5 6 7 8

E

D

C

B

A